

ORCHESTRA.

FLAUTI (SOLO ANCHE FL-PICC) FL
 OBOI OB
 CLARINETTI IN SIB (SOLO ANCHE CL-PICC) CL
 FAGOTTI FAG
 CORNI IN FA COR
 TROMBE IN SIB TR
 TROMBONI TRBN

BATTERIA (4 ESECUTORI) BAT

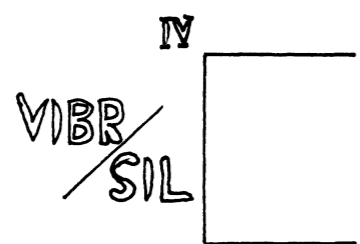
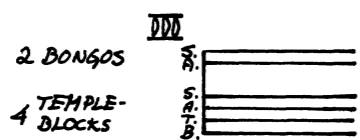
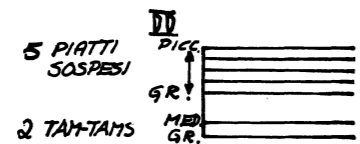
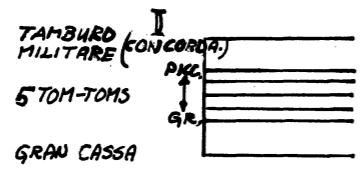

CEMBALO/CELESTA (2 ESECUTORE) CEM/CEL

PIANOFORTI (3 ESECUTORI) PF

VIOLINI I VL I

VIOLINI II VL II

VIOLE VLE

VIOLONCELLI VCL

CONTRABASSI CB

DISPOSIZIONI.

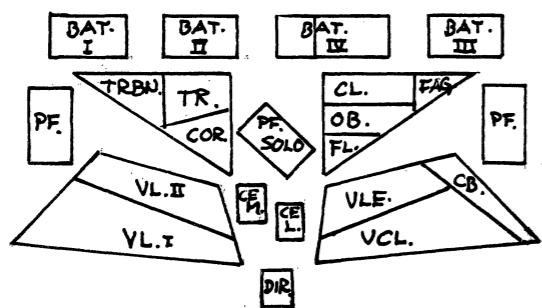

DURATA: 11'

INSTRUCTIONS.

WITH SOME EXCEPTIONS - EXACTLY NOTATED PITCHES - THE NOTATION IN THIS PIECE IS IN DOUBLE MEANING "OPTICAL" AND BOTH THE TIME AND THE PITCH ARE TO BE READ AND INTERPRETED VISUALLY AND INDIVIDUALLY.

THERE IS ONLY ONE PART FOR LET US SAY FLUTE BUT THIS PART SHALL BE PLAYED BY ALL FLUTE-PLAYERS, INDIVIDUALLY INTERPRETED, SIMILARLY THE OTHER PARTS. (EXCEPTION: BAT, CEM/CEL, PF SEE 'ORCHESTRA'.)

THE NUMBER OF THE PLAYERS OF EACH PART IS NOT FIXED. THE FOLLOWING MINIMA-DIRECTIONS MUST HOWEVER BE NOTICED:

ALL PARTS OF WIND AND BRASS INSTRUMENT MIN: 2 PLAYERS.
 VL I MIN: 10 PLAYERS.
 VL II MIN: 10 PLAYERS.
 VLE MIN: 8 PLAYERS.
 VCL MIN: 8 PLAYERS.
 CB MIN: 4 PLAYERS.

TIME: 1 CM = 1 SEK (EXCEPTION: PAGE XVIII)

THE TIME IS DIVIDED INTO PERIODS OF DIFFERENT LENGTH. THE CONDUCTOR INDICATES THE BEGINNING OF EACH PERIOD (WITH A PLAIN SIGN). HE CAN ALSO BUT ONLY IF IT'S ABSOLUTELY NECESSARY INDICATE EVERY SECOND. IT IS FORBIDDEN TO 'WRITE OUT SECONDS' IN THE PARTS.

SYNCHRONIZED PERFORMANCE: ONLY ON THE INDICATION-SIGN ↓

PITCH:

THE WHOLE REGISTER OF AN INSTRUMENT IS INDICATED BY THE FRAME:

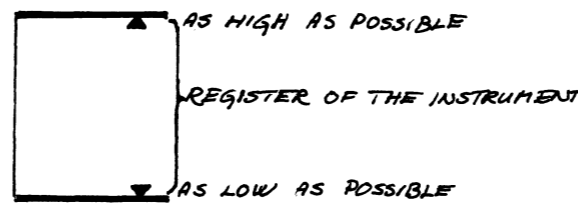

THIS IS A VERY FREE PITCH-NOTATION AND THE PLAYERS OF SAME PART MUSTN'T TRY TO GET THE SAME PITCH.

(FOR SOME OF THE PLAYERS THE REGISTER SOMETIMES CHANGES FOR INSTANCE STRINGS: HARMONICS; FL, CL: SOLO CHANGING TO PICC.)

ABBREVIATIONS AND SYMBOLS.

• • = SHORT NOTES

— = LONGER NOTES (LENGTH OF NOTES DECIDED BY LENGTH OF STROKES)

(3) [group of notes] = AS RAPIDLY AS POSSIBLE
 THE NUMBER OF NOTES IS ONLY FIXED WHEN THE GROUP IS MARKED WITH A FIGURE. (3)

THE NUMBER OF NOTES IS ALSO RATHER FREE IN GROUPS LIKE: • • • • • ; • • • • • • • • • •

[box with note] = PLACE THE NOTE FREELY IN THE PERIOD

[wavy line] = VIBRATO, LENTO (GLISS.) (1/4 TONE-DIFF.)

[wavy line with TR] = TRILLO (ROLL), PRESTO (AD LIB. 1/2 TONE / 1 TONE)

[dashed line with X] = VERY RAPID, NON RHYTHMICAL TREMOLO

[dashed line with X] = "FLATTERZUNGE"

[dashed line with X] = STROKE THE STRINGS (THE SKIN) PF (BAT)

[circle with X] = BLOWING WITHOUT PRODUCTION OF TONE

[upward arrow] = DIETRO IL PONTICELLO

[box with X and TR] = PERCUSSION EFFECT ON THE INSTRUMENT. THE POSITIONS INDICATE DIFFERENT TIMBRES. (TRY TO FIND OUT THE MOST SUITABLE).

○ — ○ = NATURAL HARMONICS
 PF: THE PITCH INDICATES THE POINT OF TOUCH.

◇ — ◇ = ARTIFICIAL HARMONICS.

X = BATT: MUFFLED INSTRUMENT WITH ONE HAND
 PF: MUFFLED STRINGS (VERY STRONGLY, WITH FOUR FINGERS.)

♀ = "PIZZ. DI BARTOK"

○ = SOFT STICK (BAT. I, II, III, IV, PF.)

● = HARD STICK (BAT. I, II, III, IV, PF.)

∩ = DRUM STICK (BAT. I, II, III)

∩ = METAL STICK (RATHER THICK) (BAT. II, PF)

∩ = TAM-TAM STICK (BAT. II)

∩ = SOFT BRUSH (PF)

∩ = HAND (BAT. I, PF)

∩ = CON SORD.

∩ = SENZA SORD.

SP. = SUL PONTICELLO

ST. = SULLA TASTIERA

ORD. = ORDINARIO

C.L. BATT. = COL LEGNO BATTUTO

∩ = STRAIGHT SORD.

∩ = CUP SORD.

5" 5" 4" 3" 5" 5" (31)

FL
(SOLO ANCHE FL-PICC.)

OB

CL
(SOLO ANCHE CL-PICC.)

FAG

COR

TR

TRBN

BAT

I TAMBURO MILITARE
TOM-TOMS
GRAND CASSA

II PIATTI SOSPESI
TAM-TAMS

III BONGOS
TEMBALE
BLOCS

IV SIL
(VIBR.)

CEM
(CEL.)

PF

VL I

VL II

VLE

VCL

CB

SOLO

pp mp pppp

pp mp ppp (L.V.)

TUTTI

ppp PED. CORDES

p > ppp mp (PED. TUTTI)

SOLO (FLAG)

TUTTI PIZZ. TREM.

p

ppp

MI GLI ALTRI CORDE

p ppp

TUTTI SP. ORD.

mf p

TUTTI ST. ORD.

ppp CRESC. p ORD. SP. ORD.

TUTTI ST. ORD. NON CRESC.

ppp CRESC. p (GLISS.) (ORD.) SP.

15" 4" 5" 5" 5" 5" 5" (1'32")

FL
TUTTI
p
PPP

OB
TUTTI
mf
TR
SOLO
GLISS
TUTTI
TUTTI (3)
TR
P

CL
TUTTI
mp
R
PPP
TUTTI
p
TR
PP

FAG
TUTTI
pp
TR
mf
SOLO
SOLO
TUTTI
TR
P

COR
SOLO
mf
TUTTI
SOLO
TUTTI
p
mf
p
TR

TR
SOLA
mf
TR
SOLA
mf

TRBN
SOLO
pp
TUTTI
GLISS
p
mf
p
TR

BAT
I
TAMBURO MILITARE
TOM-TOMS
GRAND CASSA
II
PIATTI SOSPESI
TAM-TAMS
III
SONGOS
TEMPLE BLOCKS
IV
SIL

GEM
PF
(PED)
SOLO PED.
p
f
mf
ff
(TUTTI)

VL I
3 SOLI
PP
ORD.
SP.
TUTTI
ORD.
SUB.
mf

VL II
3 SOLI
ORD.
PP
ORD.
SP.
TUTTI
ORD.
SUB.
mf

VLE
2 SOLI
ORD.
PP
ORD.
SP.
ORD.
mp
TUTTI
SUB.
GLISS.
mf

VCL
2 SOLI
ORD.
PP
ORD.
SP.
ORD.
mp
TUTTI
SUB.
GLISS.
mf

CB
2 SOLI
ORD.
PP
ORD.
SP.
TUTTI
ORD.
SUB.
mf

1" 2" 3" 4" (25) 2" 1.5" 1.5" 2" 30 5" 4" 5" (2'03')

FL SOLO (4) TUTTI (3) (SOLO MUTA IN FL-PIC.) TUTTI E CON FL-PIC. TUTTI MA SENZA FL-PIC. TUTTI E CON FL-PIC. (3) (3)

OB SOLO (3) TUTTI (3) (4) (3)

CL SOLO (5) TUTTI P R (SOLO MUTA IN CL-PIC.) TUTTI E CON CL-PIC. TUTTI MA SENZA CL-PIC. GL-PIC. GLI ALTRI

FAG TUTTI P SOLO MP GLI ALTRI SOLO MP GLI ALTRI

COR TUTTI P TUTTI P SOLO GLI ALTRI

TR TUTTE P R TUTTE P SOLA LE ALTRE

TRBN TUTTI P SOLO GLI ALTRI MP SOLO GLI ALTRI

BAT

I TAMBURO MILITARE TR PP TR PP TR PP

II TOM-TOMS TR PP TR PP TR PP

III GRAND CASSA TR PP TR PP TR PP

PIATTI SOSPESI TR PP TR PP TR PP

TAM-TAMS TR PP TR PP TR PP

IV BONGOS TR PP TR PP TR PP

SIL TEMPLE BLOCKS TR PP TR PP TR PP

IV SIL VIBR (P) CON VIBRATO (SLOW) PED P

CEM L.V. A NIENTE.

PF TUTTI PED CORDE PPP (mf) TUTTI PED CORDE

VL I (ORD) → SP. (SP) P ORD DIV. A 2 PARTE

VL II (ORD) → SP. (SP) P ORD DIV. A 2 PARTE

VLE (ORD) → SP. (SP) P ORD DIV. A 2 PARTE

VCL (ORD) → SP. (SP) P ORD DIV. A 2 PARTE

CB (ORD) → SP. (SP) P ORD DIV. A 2 PARTE

3" 4" 5" 5" 10" 4" (2' 34')

FL
 SOLO FL-PICC.
 SOLO FL-PICC. GLI ALTRI (QUASI GLISS)
 TUTTI E CON FL-PICC.
 (SOLO MUTA IN FL-GR.)

OB
 TUTTI
 TUTTI

CL
 TUTTI MA SENZA CL-PICC.
 SOLO CL-PICC.
 TUTTI MA SENZA CL-PICC.
 (SOLO MUTA IN CL-SOB)

FAG
 TUTTI
 TR
 SOLO
 SOLO
 (SOLO)
 TUTTI
 (SOLO)
 *TUTTI E CON CL-PICC.

COR
 TUTTI
 SOLO
 TUTTI

TR
 TUTTI
 SOLO
 TUTTI

TRBN
 TUTTI
 SOLO
 TUTTI

BAT
 I
 TAMBURO MILITARE
 TOM-TOMS
 GRAND CASSA
 II
 PIATTI SOSPESI
 TAN-TANS
 III
 BONGOS
 TEMPLE BLOCKS
 IV
 VIBR
 PED
 SIL
 VIBR
 CON VIBRATO (FAST) PED

CEM
 MAN: I
 TR
 MAN: II

PF
 TUTTI PED.
 TUTTI
 (CORDE)
 TUTTI
 PED

VL I
 PIZZ
 TUTTI
 ARCO
 PIZZ
 TUTTI
 ARCO

VL II
 TUTTI
 PIZZ
 PIZZ
 TUTTI
 ARCO

VLE
 TUTTE
 PIZZ
 PIZZ
 TUTTI
 ARCO

VCL
 TUTTI
 PIZZ
 1 SOLO
 2 SOLI
 TUTTI
 (TUTTI)

CB
 TUTTI PIZZ
 1 SOLO
 2 SOLI
 TUTTI
 (TUTTI)